

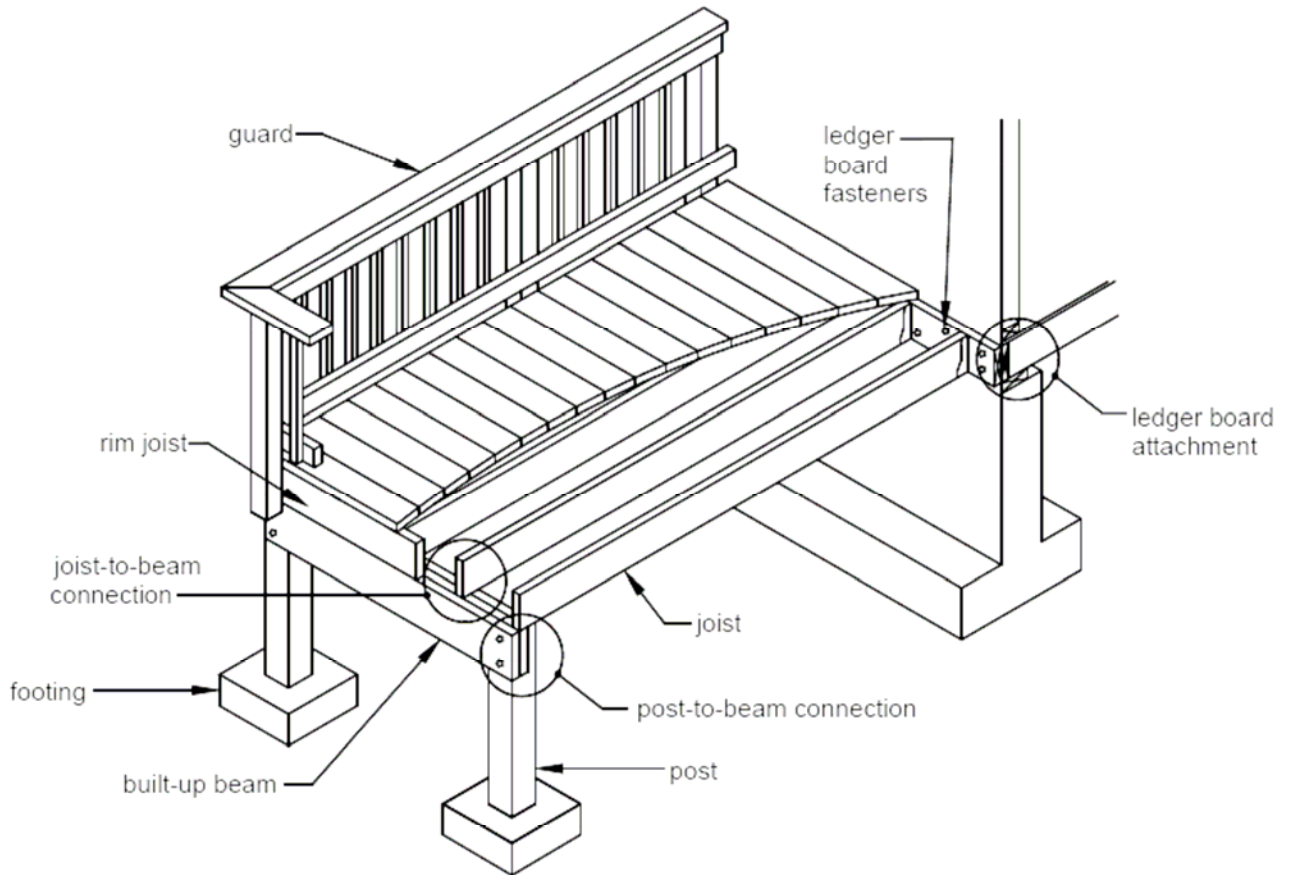

Typical Deck Details

Based on the 2004 Residential Code of Ohio



Contents

General Notes	2	Rim Joist Requirements.....	10
Joist Size.....	3	Built-up Beam Requirements	10
Beam Size	4	Post-to-Beam Connection.....	10
Ledger Attachment Requirements	4	Footings	11
Prohibited Ledger Attachments	6	Guard Requirements.....	11
Ledger Board Fasteners	6	Stair Requirements	14
Free-Standing Decks	8	Stair Handrail Requirements	15
Lateral Support of Free-Standing Decks	8	Stairway Illumination Requirements.....	16
Joist Hangers	9	Framing at Chimney or Bay Window	16
Joist-to-Beam Connection	9		

THE USE OF THIS PACKAGE IN LIEU OF SUBMITTED DRAWINGS APPLIES TO SINGLE SPAN, SINGLE LEVEL, RESIDENTIAL DECKS ONLY. DECKS MUST BE CONSTRUCTED IN STRICT CONFORMANCE WITH THE DETAILS CONTAINED HEREIN. A COPY OF THIS DECK DETAIL MUST BE ON THE JOB SITE AND AVAILABLE TO THE INSPECTOR DURING THE INSPECTION PROCESS.

GENERAL NOTES

1. All lumber shall be southern pine, grade #2 or better and shall be pressure treated ACQ or CA-B in accordance with American Wood-Preservers' Association standards for **ground contact**.
2. All nails shall be spiral or annular grooved.
3. **New pressure treatment methods use chemicals that will prematurely corrode standard fasteners, hardware, and flashing when in contact with pressure treated lumber, and, as a result, fastener and hardware requirements have changed; see below.**
 - All screws and nails shall be hot-dipped galvanized or stainless steel.**
 - All hardware (joist hangers, cast-in-place post anchors, etc.) shall be galvanized with 1.85 oz/sf of zinc (G-185 coating) or shall be stainless steel. Look for products such as "Zmax" from Simpson Strong-Tie or "Triple Zinc" from USP.**
4. Decks constructed according to this handout are not approved for future hot tub installations.
5. Decks shall not be attached to house overhangs, bay windows, brick veneers, or chimneys.
6. Deviations from this handout and conditions which do not meet the details shown herein require a plan submission.
7. Inspections:
 - A footing, framing, and final inspection is required on all decks.
 - Footing inspections are required PRIOR to the placement of concrete.
 - Framing and final inspections may be combined if all portions of the deck framing and mechanical attachments are at least 42" above grade.
 - Inspections are required by law. Failure to receive any and all inspections can result in the issuance of violations which may lead to legal proceedings.**
8. It is the responsibility of the permit holder or the permit holder's representative to notify the City when the stages of construction are reached that require an inspection. Inspection requests may be made using one of the three methods listed below; please have your permit number available when scheduling an inspection.
9. All decking material shall be composed of 2x6 or 5/4 ("five-quarter") board. Attach decking to each joist with 2-8d nails or 2-#8 screws. Decking may be placed from an angle perpendicular to the joists to an angle of 45 degrees to the joists. Decking must have a span length such that each board bears on a minimum of 4 joists.
10. Plastic or manufactured decking products may be substituted with an approved evaluation report from the International Code Council. The evaluation report must be on the jobsite and available to the inspector during the inspection process. Installation and span lengths of the substituted material must be in strict conformance with the evaluation report and the manufacturer's instructions.
11. Decks shall not be used or occupied until a final inspection approval is obtained.

JOIST SIZE

The span of a joist is measured from the centerline of bearing at one end of the joist to the centerline of bearing at the other and does not include overhangs. Maximum joist span lengths are noted in TABLE 1.

See **FIGURE 1** and **FIGURE 2** for joist span types.

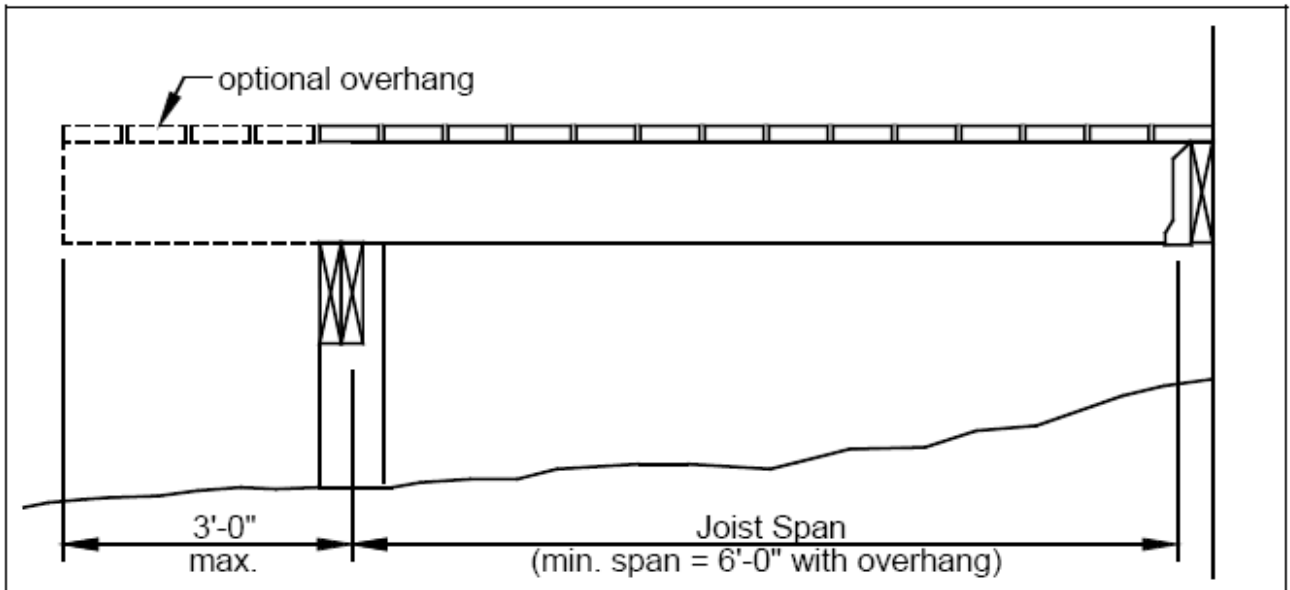

FIGURE 1: JOIST SPAN - DECK ATTACHED AT HOUSE

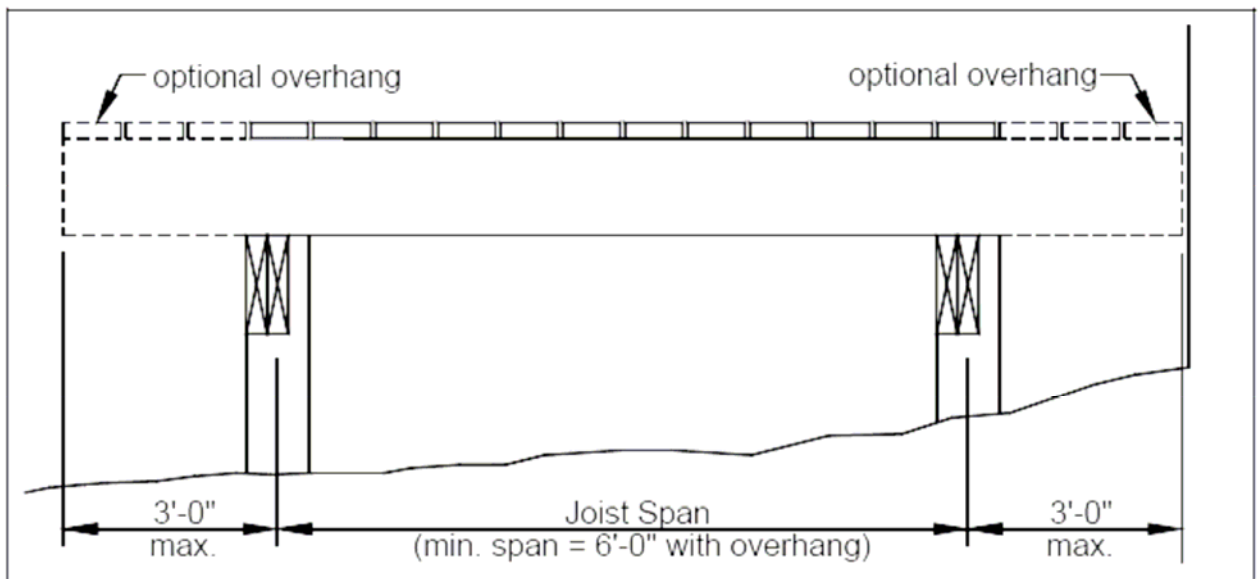

FIGURE 2: JOIST SPAN - FREE-STANDING DECK

Joist Size	Joist Spacing , on center	Joist Span
2x6	16"	9' 4"
2x6	24"	7' 10"
2x8	16"	12' 2"
2x8	24"	10' 1"
2x10	16"	15' 9"
2x10	24"	13' 1"
2x12	16"	18' 9"
2x12	24"	15' 4"

BEAM SIZE

Beam size determination is based on your joist span characteristics. Use TABLE 2 if your joists do not overhang or TABLE 3 if your joist overhangs. See FIGURE 3 for beam span types.

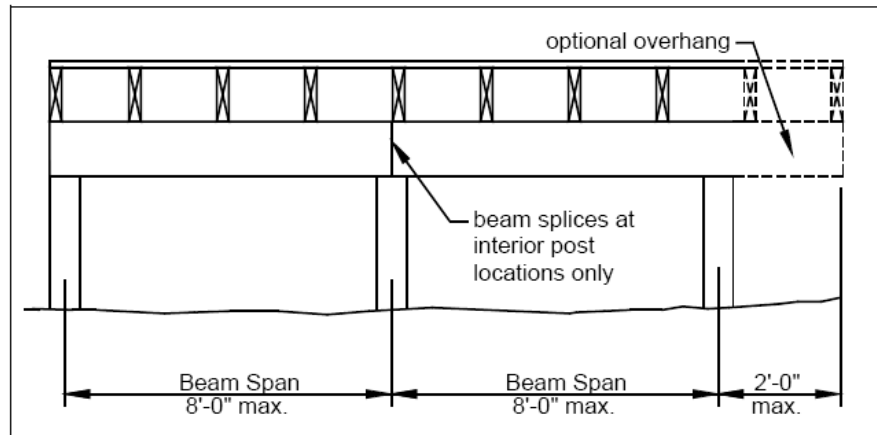

FIGURE 3: BEAM SPAN TYPES

TABLE 2: MINIMUM BEAM SIZE FOR JOISTS WITH NO OVERHANGS

Joist Span	Beam Size
0 - 6'-8"	(2) 2x6*
6'-8" - 11'-2"	(2) 2x8*
11'-2" - 15'-9"	(2) 2x10*
16'-0" - 18'-9"	(2) 2x12

TABLE 3: MINIMUM BEAM SIZE FOR JOISTS WITH OVERHANGS

Joist Span	Beam Size
0 - 6'-0"	(2) 2x8*
6'-0" - 12'-8"	(2) 2x10*
12'-8" - 18'-9"	(2) 2x12

* You may substitute a larger beam size for the one shown in the table. For instance, if the table requires (2) 2x8, you may substitute a (2) 2x10 or (2) 2x12.

LEDGER ATTACHMENT REQUIREMENTS

GENERAL: Ledger board attachments to the existing exterior wall shall be constructed in accordance with FIGURE 5 through FIGURE 7. When attachments are made to the existing house band board, it shall be capable of supporting the new deck. If this cannot be verified or conditions at the existing house differ from the details herein, then a free-standing deck is required. See FREE-STANDING DECKS on sheet 8. YOU MUST VERIFY THE EXISTING CONDITIONS IN THE FIELD PRIOR TO APPLYING FOR A BUILDING PERMIT. COMPLIANCE WITH ALL THE REQUIREMENTS HEREIN IS CRITICAL TO ENSURE THE STRUCTURAL STABILITY OF YOUR DECK.

SIDING AND FLASHING: Siding or the exterior finish system must be removed prior to the installation of the ledger board. Flashing is required at any ledger board connection to a wall of wood framed construction and shall be composed of copper (attached using copper nails), stainless steel, UV resistant plastic or galvanized steel coated with 1.85 oz/sf of zinc (G-185 coating).

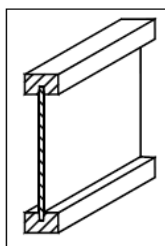

FIGURE 4: MWJ PROFILE

MANUFACTURED WOOD JOIST: The term "MWJ" denotes manufactured wood "I" joists; see FIGURE 4. Examples of manufactured wood joists are TJI, GPI, and LPI. Many new homes constructed with MWJs include a 1-1/4" manufactured solid rim joist; see FIGURE 5. However, older homes constructed with MWJs may only include a plywood band board. In these cases a freestanding deck or a full plan submission is required.

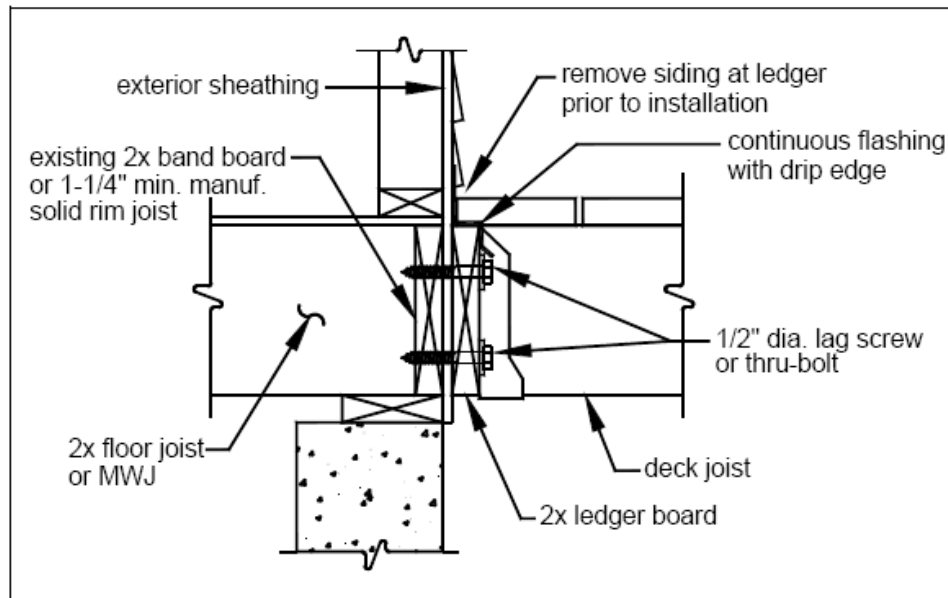

FIGURE 5: ATTACHMENT OF LEDGER BOARD-TO-BAND BOARD

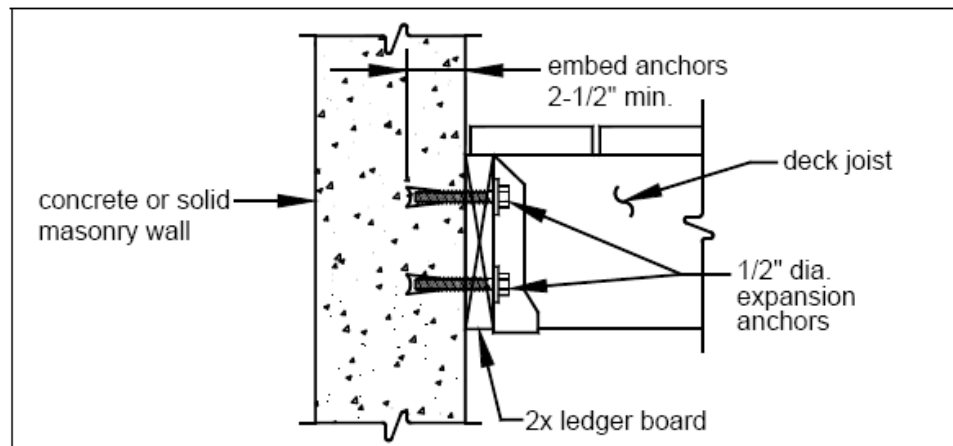

FIGURE 6: ATTACHMENT OF LEDGER BOARD-TO-FOUNDATION WALL (CONCRETE OR SOLID MASONRY)

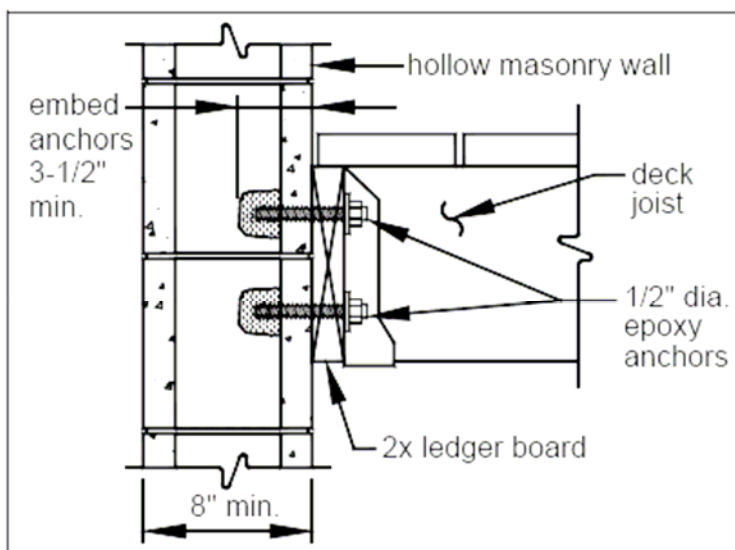

FIGURE 7: ATTACHMENT OF LEDGER BOARD-TO-FOUNDATION WALL (HOLLOW MASONRY)

PROHIBITED LEDGER ATTACHMENTS

Attachments to the ends of pre-manufactured open web joists, to brick veneers, and to house overhangs are strictly prohibited; see FIGURE 8 through FIGURE 10. In such cases the deck shall be free-standing. See FREE-STANDING DECKS on sheet 8.

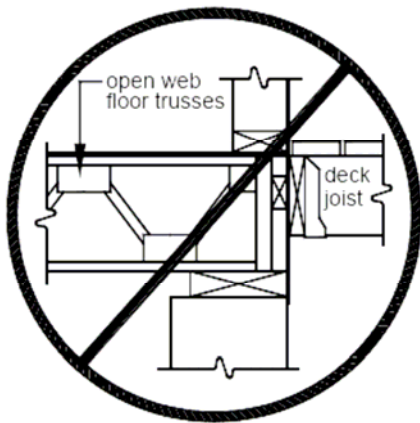

FIGURE 8: NO ATTACHMENT TO OPEN WEB TRUSSES

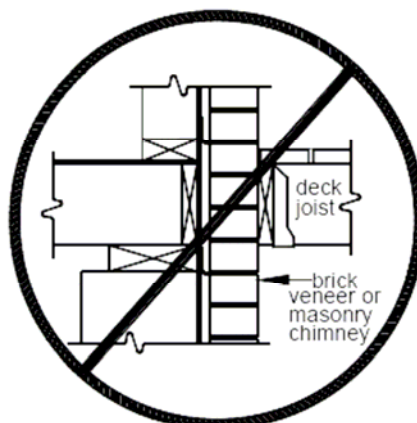

FIGURE 9: NO ATTACHMENT TO BRICK VENEER

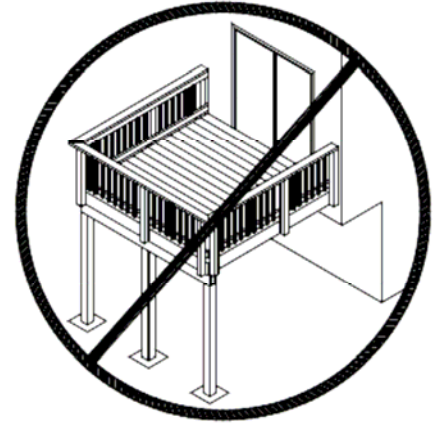

FIGURE 10: NO ATTACHMENT TO HOUSE OVERHANG

LEDGER BOARD FASTENERS

All fastener types shall be spaced per TABLE 4 and installed per FIGURE 11. All fasteners shall be installed with washers and must be thoroughly tightened. **Adequacy of connections will be verified by county inspectors.** If a ladder is required to access the ledger board, one must be provided by the property owner, permit holder, or their representative.

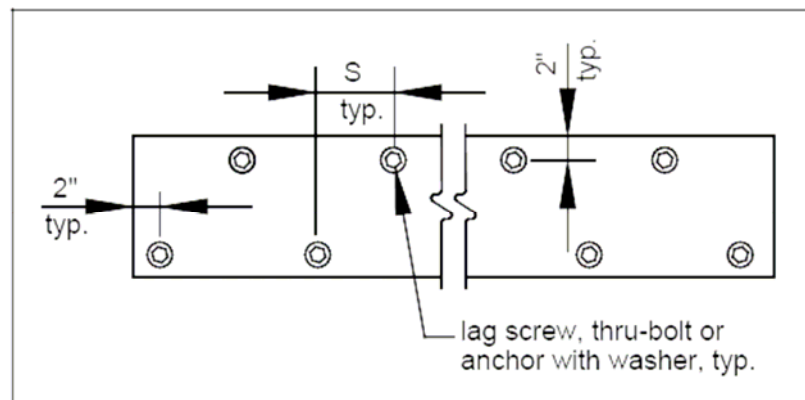

FIGURE 11: LEDGER BOARD FASTENER SPACING AND CLEARANCES

TABLE 4: LEDGER BOARD FASTENER SCHEDULE

Joist Span	S (spacing), on center
0 – 8'	10"
8' – 10'	8"
10' – 14'	6"
14' – 18'	5"
greater than 18'	4"

Thru-Bolts

Thru-bolts shall have a minimum diameter of $\frac{1}{2}$ ". Lead (pilot) holes for thru-bolts shall be $\frac{17}{32}$ " to $\frac{9}{16}$ " in diameter. Thru-bolts must be equipped with washers at the bolt head as well as the nut.

Expansion Anchors

Use expansion anchors when attaching a ledger board to a concrete or solid masonry wall as shown in FIGURE 6. Bolt diameters of the anchors shall be a minimum of $\frac{1}{2}$ "; in some cases, this may require an anchor size of $\frac{5}{8}$ ". Minimum embedment length shall be $2\text{-}\frac{1}{2}$ ". Expansion anchors must have washers.

Epoxy Anchors

When attaching to hollow masonry, fill the cells with grout and use expansion anchors, or use one of the approved epoxy anchors listed in TABLE 5 and install as shown in FIGURE 7. Epoxy anchors shall have a minimum diameter of $\frac{1}{2}$ " and minimum embedment length of $3\text{-}\frac{1}{2}$ ". Installation shall be in strict conformance to the manufacturers' instructions. Epoxy anchors must have washers.

TABLE 5: APPROVED EPOXY ANCHORS

Manufacturer	Product
ITW Ramset/Red Head	Epcon Acrylic 7
Hilti	HY-20

Lag Screws

Lag screws shall have a minimum diameter of $\frac{1}{2}$ " and shall be hot-dipped galvanized or stainless steel.

Lag screws may be used only when the field conditions match those shown in FIGURE 5. **You must verify the existing conditions in the field prior to applying for a building permit and installing lag screws. Compliance with all the requirements herein is critical to ensure the structural stability of your deck.** See FIGURE 12 for lag screw length and shank requirements. All lag screws shall be installed with washers.

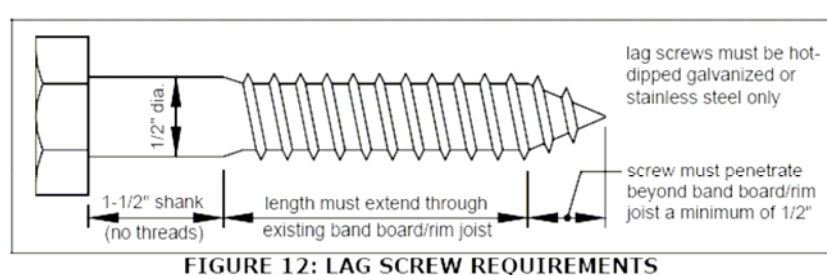

FIGURE 12: LAG SCREW REQUIREMENTS

Lag screw installation requirements: each lag screw shall have lead (pilot) holes drilled as follows: 1) drill a $\frac{1}{2}$ " diameter hole in the ledger board, 2) drill a $\frac{5}{16}$ " diameter hole into the solid connection material of the existing house. **DO NOT DRILL A $\frac{1}{2}$ " DIAMETER HOLE INTO THE SOLID CONNECTION MATERIAL.**

The threaded portion of the lag screw shall be inserted into the lead hole by turning. **DO NOT DRIVE WITH A HAMMER.** Use soap or a wood-compatible lubricant as required to facilitate tightening. Each lag screw shall be thoroughly tightened.

FREE-STANDING DECKS

Decks which are free-standing do not utilize the exterior wall of the existing house to support vertical loads. Support at or near the house is provided by an additional beam and posts. See FIGURE 13. Beam size is determined by TABLE 2 and TABLE 3.

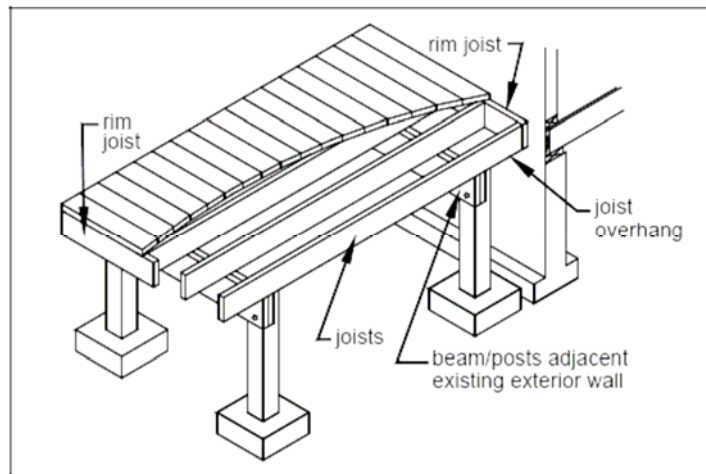

FIGURE 13: FREE-STANDING DECK

LATERAL SUPPORT OF FREE STANDING DECKS

Free standing decks greater than 2 feet above grade shall resist lateral loading and movement by one of the following methods.

1. **Diagonal Bracing:** provide diagonal bracing as shown in FIGURE 14. Bracing shall be located between posts parallel to beams and bolted to the beam and post as shown. Diagonal bracing shall also be located perpendicular to beams and, in such cases, bracing shall be bolted to the post and joist above the post location.

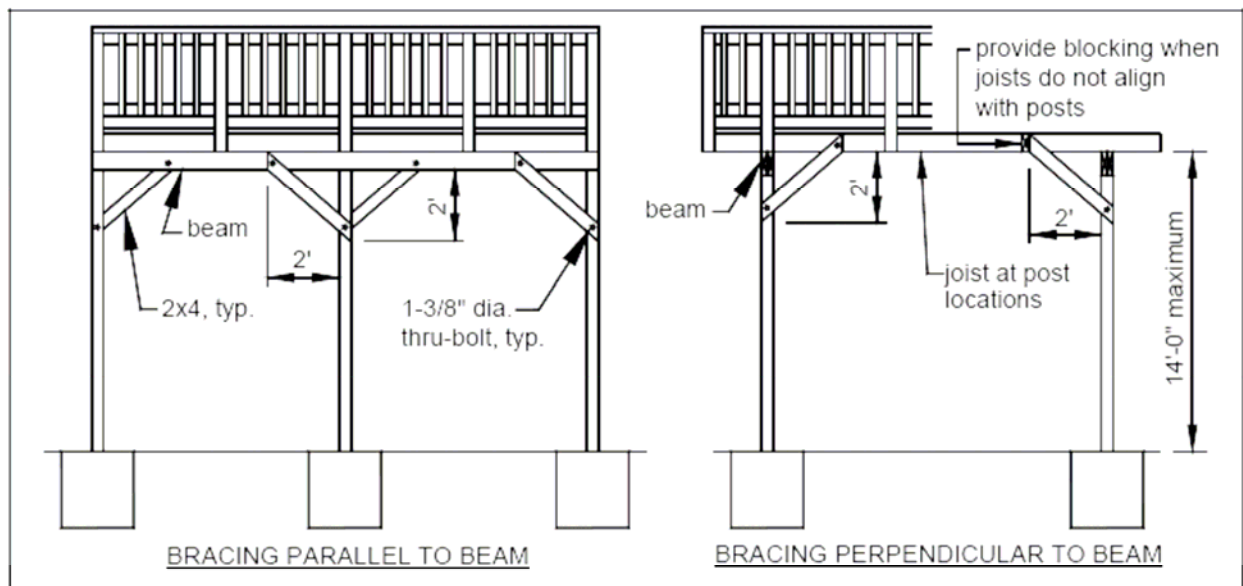

FIGURE 14: DIAGONAL BRACING REQUIREMENTS

2. Attachment To House: lateral support is provided by the attachment of the deck rim joist to the existing house as shown in FIGURE 15. The existing exterior wall must have sheathing consisting of structural wood panels with a minimum thickness of $\frac{3}{8}$ ", and the fasteners shall attach to an existing band board or wall stud. The deck rim joist may also attach to a masonry or concrete wall, but not to a brick veneer. YOU MUST VERIFY THIS CONDITION IN THE FIELD PRIOR TO UTILIZING THIS METHOD. Fasteners shall be 16" on center and must penetrate existing wall studs. See also the provisions noted on sheet 6. Flashing over the rim joist is required and must be installed in accordance with the flashing provisions noted on sheet 4. For rim joist size and requirements, see sheet 10.

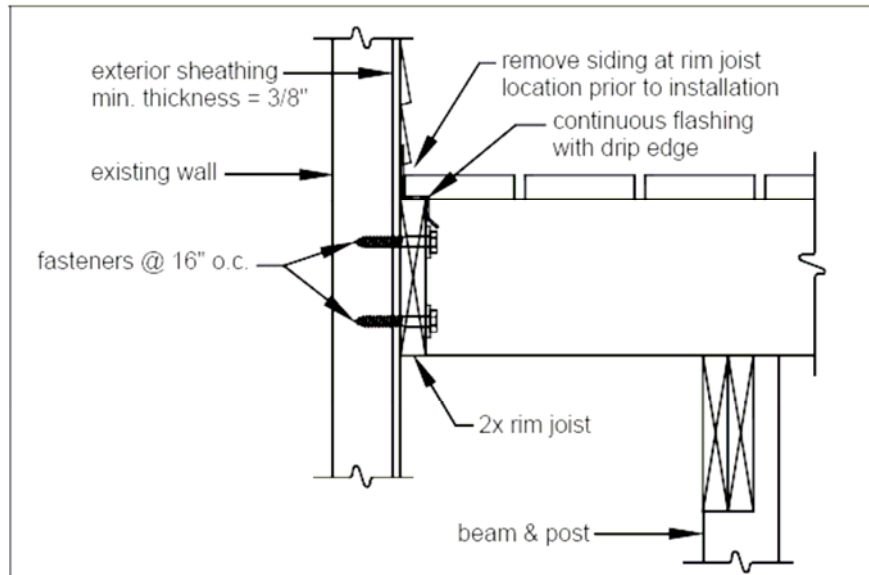

FIGURE 15: ATTACHMENT TO HOUSE LATERAL SUPPORT

JOIST HANGERS

Joist hangers, as shown in FIGURE 16, shall have a minimum capacity of 1000 lbs. Joist hangers used shall be manufactured for their intended lumber size. Joist hangers shall be galvanized with 1.85 oz/sf of zinc (G-185 coating) or shall be stainless steel.

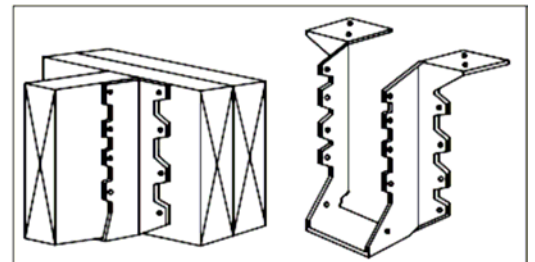

FIGURE 16: TYPICAL JOIST HANGERS

JOIST-TO-BEAM CONNECTION

Each joist shall be attached to the beam as shown in FIGURE 17. Mechanical fasteners shall be galvanized with 1.85 oz/sf of zinc (G-185 coating) or shall be stainless steel.

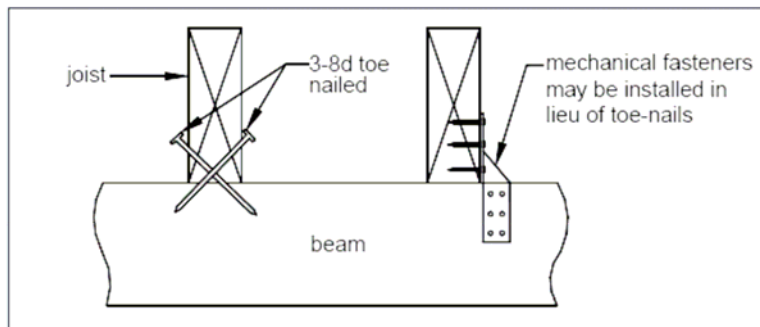

FIGURE 17: JOIST-TO-BEAM DETAIL

RIM JOIST REQUIREMENTS

Attach a continuous rim joist to the ends of joists as shown in FIGURE 18. Please note: rim joists are required at both ends of joists associated with free-standing decks. Minimum rim joist dimensions shall be equal to the dimensions of the joist.

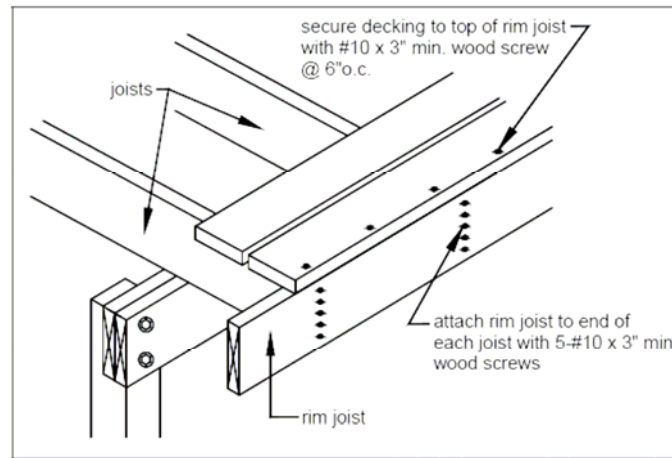

FIGURE 18: RIM JOIST CONNECTION DETAILS

BUILT-UP BEAM REQUIREMENTS

Built-up beams shall be assembled in accordance with FIGURE 19. The nailing pattern shall be staggered as shown.

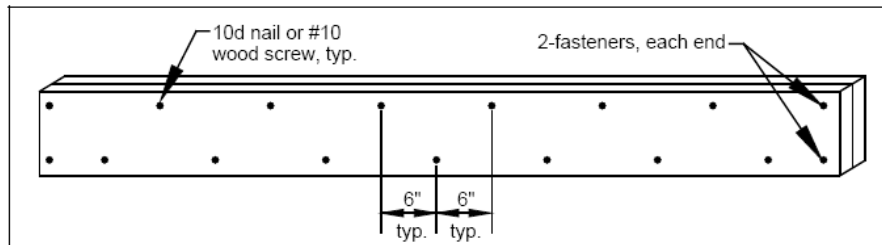

FIGURE 19: BUILT-UP BEAM DETAIL

POST-TO-BEAM REQUIREMENTS

The post-to-beam connection may be accomplished by notching the 6x6 post as shown in FIGURE 20. All thru-bolts shall have washers at the bolt head and nut. All post sizes shall be 6x6, and the maximum height shall be 14'-0".

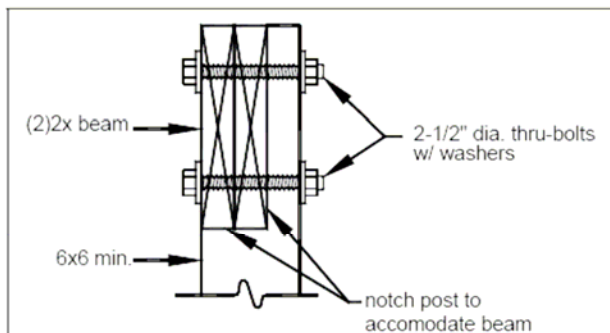

FIGURE 20: POST-TO-BEAM REQUIREMENTS

FOOTINGS

See FIGURE 21 for footing size, footing thickness and post attachment options and requirements. All footings shall bear on solid ground; bearing conditions shall be verified in the field by City inspectors prior to placement of concrete. Footings closer than 5'-0" to the existing exterior house wall must bear at the same elevation as the existing wall footing. **Do not construct footings over utility lines or enclosed meters. Call OUPS at 1-800-362-2764 2 working days before you dig.** Pre-manufactured post anchors shall be galvanized with 1.85 oz/sf of zinc (G-185 coating) or shall be stainless steel.

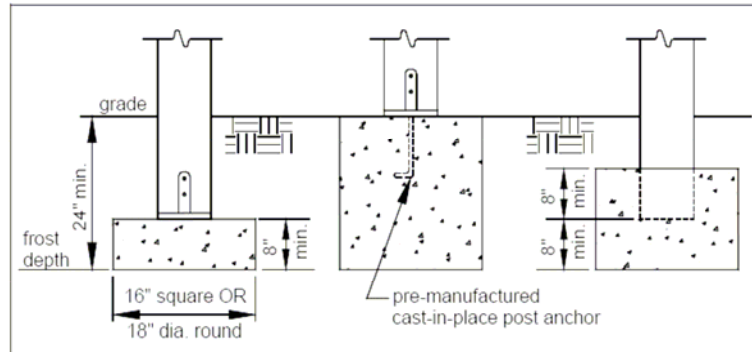

FIGURE 21: TYPICAL FOOTING DETAILS

GUARD REQUIREMENTS

Decks less than 30" above grade are not required to have a guard; however, if one is installed, it must meet these requirements. All guards shall be constructed in strict conformance with figures herein; any deviations require a plan submission.

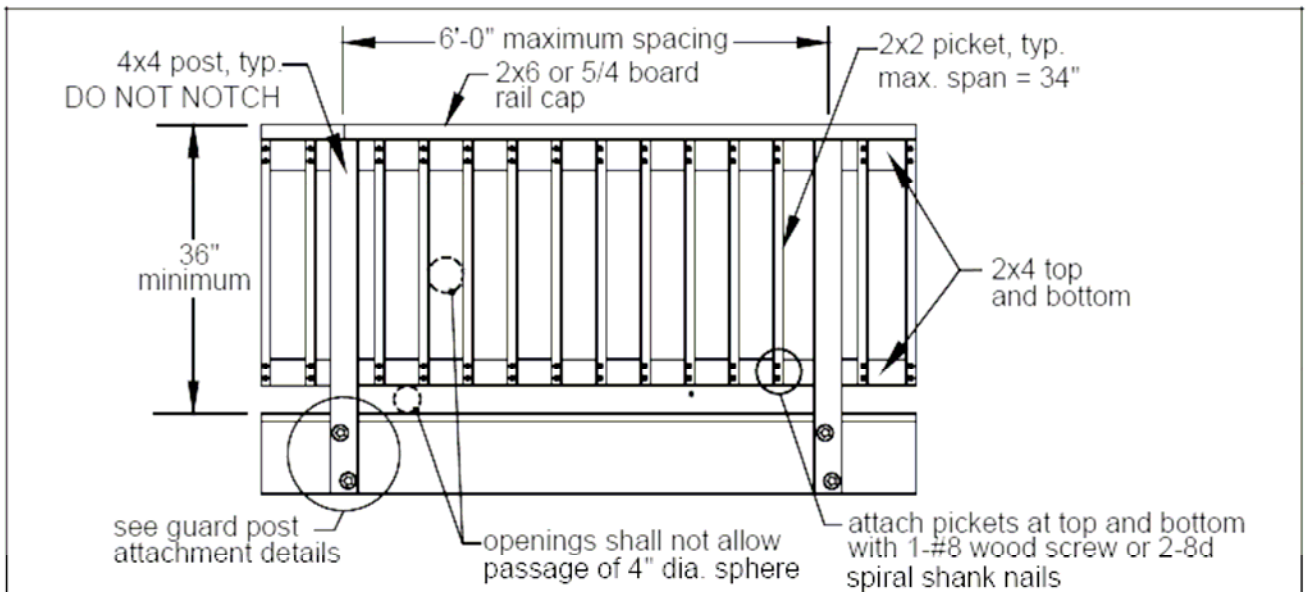

FIGURE 22: TYPICAL GUARD DETAIL

Any pre-fabricated wood, plastic or manufactured guard system purchased from a home center store, lumber company or similar will also require a plan submission. The rail cap is designed to withstand a concentrated load of 200 LBS anywhere along its length; the infill area is designed to withstand a horizontal load of 50 LBS on a square foot area.

GUARD POST ATTACHMENT: Guard posts shall be spaced per FIGURE 22 and attached per FIGURE 23 through FIGURE 26.

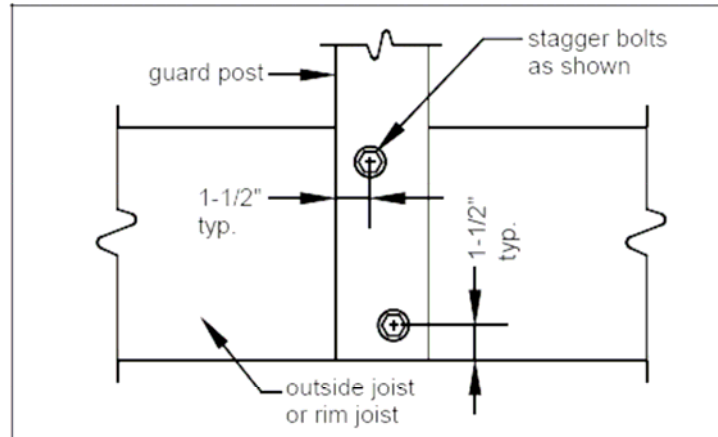

FIGURE 23: GUARD POST ATTACHMENT DETAIL

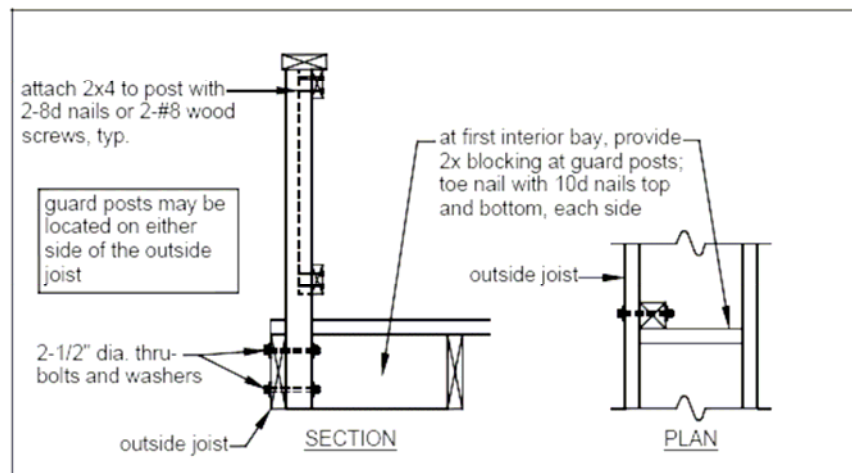

FIGURE 24: GUARD POST TO OUTSIDE JOIST DETAIL

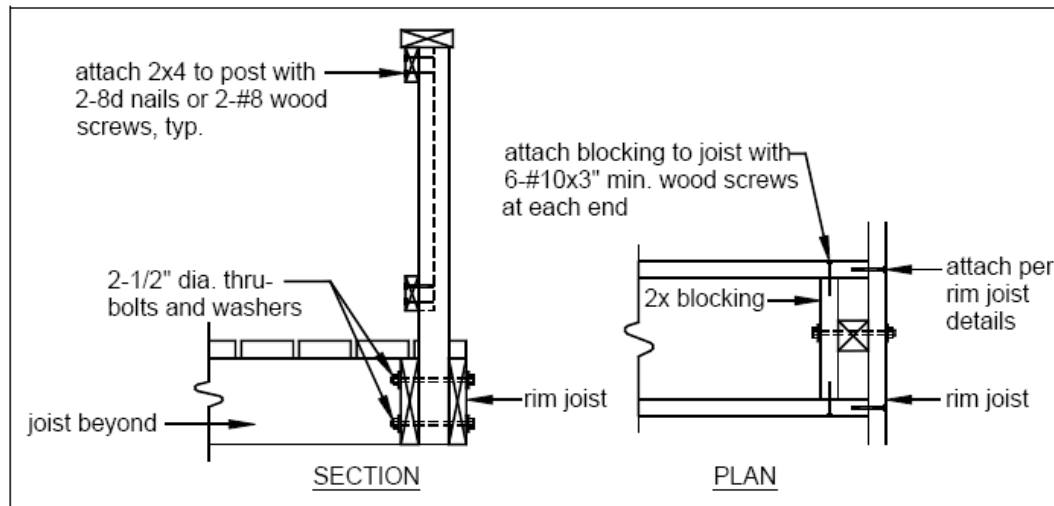

FIGURE 25: GUARD POST TO RIM JOIST DETAIL, OPTION 1

As shown in FIGURE 26, guard posts may be attached to the outside face of the rim joist. However, in this condition, and in addition to the attachment requirements shown in FIGURE 18, the rim joist must be fastened to the next adjacent joists with 20 gage. *stud tie plates* attached per the manufacturer's instructions with hot-dipped galvanized or stainless steel fasteners. Stud tie plates must be galvanized with 1.85 oz/sf of zinc (G-185 coating) or shall be stainless steel. Look for model number SP1 in a Zmax coating from Simpson Strong-Tie or model number SPT22 in a Triple Zinc coating from USP. **If you are unable to use *stud tie plates* in this condition, you must follow the requirements of FIGURE 25.**

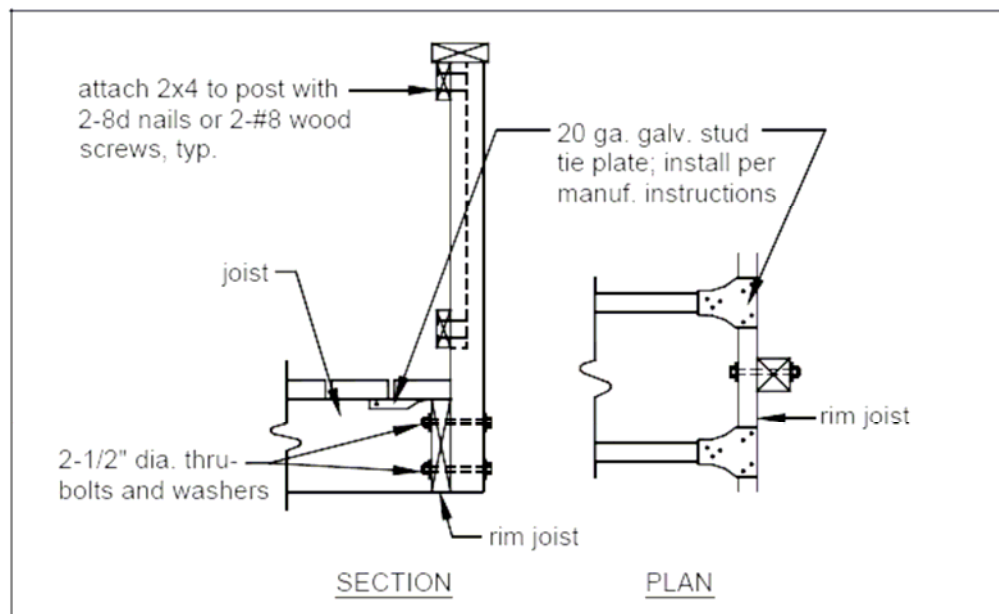

FIGURE 26: GUARD POST TO RIM JOIST DETAIL, OPTION 2

STAIR REQUIREMENTS

Stairs, stair stringers, and stair guard shall meet the requirements shown in FIGURE 27 through FIGURE 33. All stringers shall be 2x12.

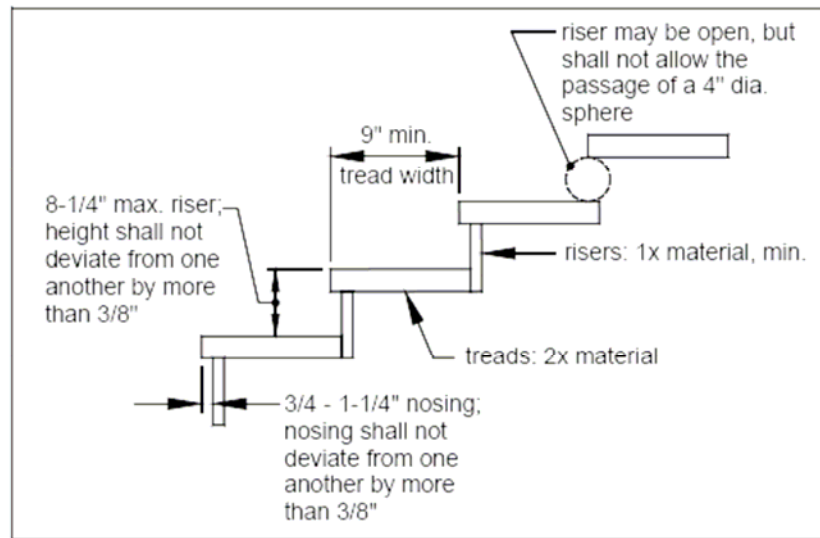

FIGURE 27: TREAD AND RISER DETAIL

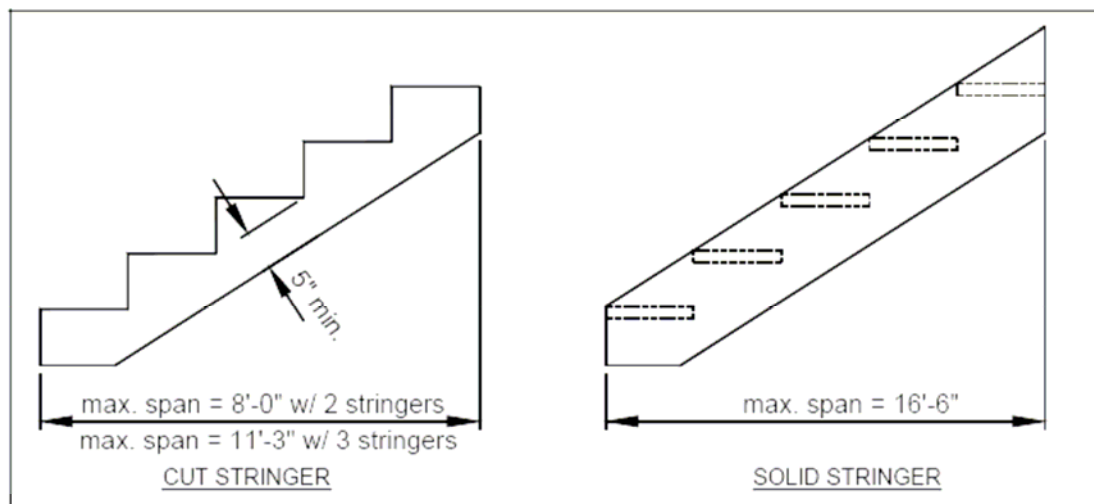

FIGURE 28: STAIR STRINGER REQUIREMENTS

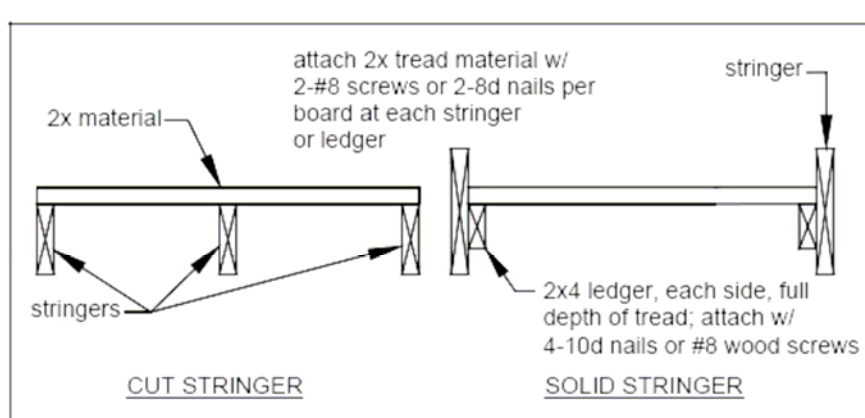

FIGURE 29: TREAD CONNECTION REQUIREMENTS

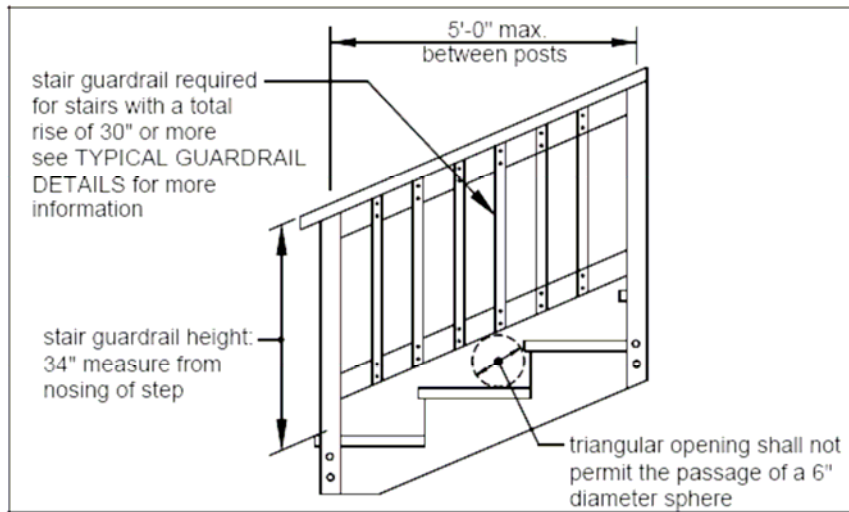

FIGURE 30: STAIR GUARD REQUIREMENTS

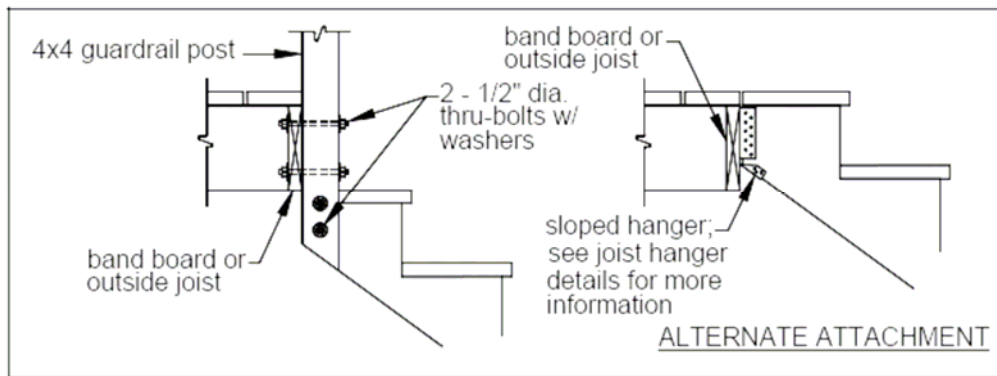

FIGURE 31: STAIR STRINGER CONNECTION DETAIL

STAIR HANDRAIL REQUIREMENTS

All stairs with 2 or more risers shall have a handrail on one side. Handrails shall be graspable and shall be composed of decay-resistant and/or corrosion resistant material. The hand grip portion, if circular, shall be between 1-1/4" and 2-1/4" in cross section. Shapes other than circular shall have a perimeter dimension between 4" and 6-1/4" with a maximum cross sectional dimension of 2-1/4". All shapes shall have a smooth surface with no sharp corners. Handrails shall run continuously from a point directly over the lowest riser to a point directly over the highest riser and shall return to the guard at each end; see FIGURE 33. Handrails may be interrupted at guards posts only at a turn in the stair. See FIGURE 32.

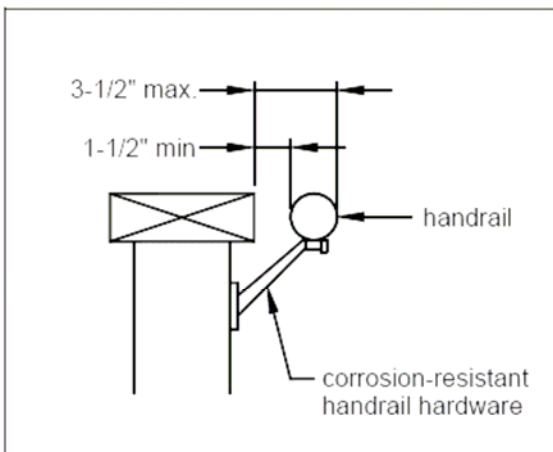

FIGURE 32: HANDRAIL REQUIREMENTS

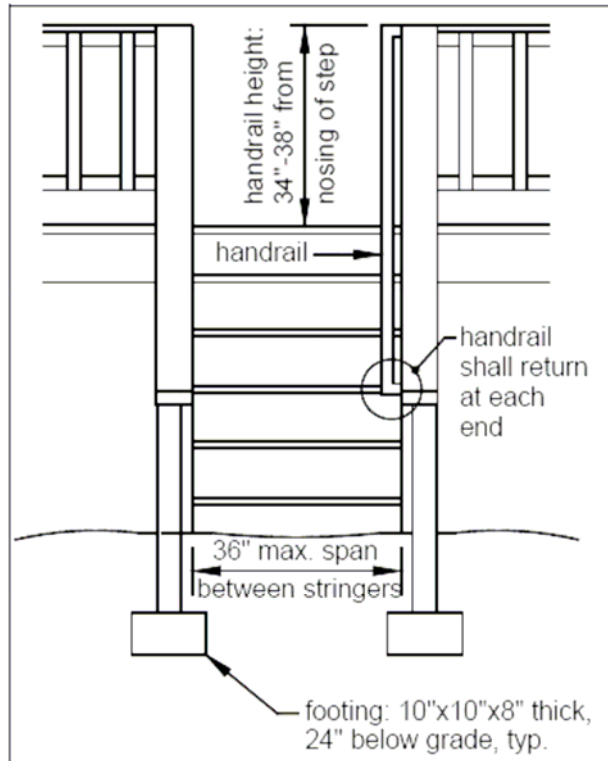

FIGURE 33: MISCELLANEOUS STAIR REQUIREMENTS

STAIR ILLUMINATION REQUIREMENTS

Stairways shall have a light source located at the top landing such that all stairs and landings are illuminated. The light switch shall be operated from inside the house.

FRAMING AT CHIMNEY OR BAY WINDOW

All members at a chimney or bay window shall be framed in accordance with FIGURE 34. Headers with a span length greater than 6'-0" require a plan submission.

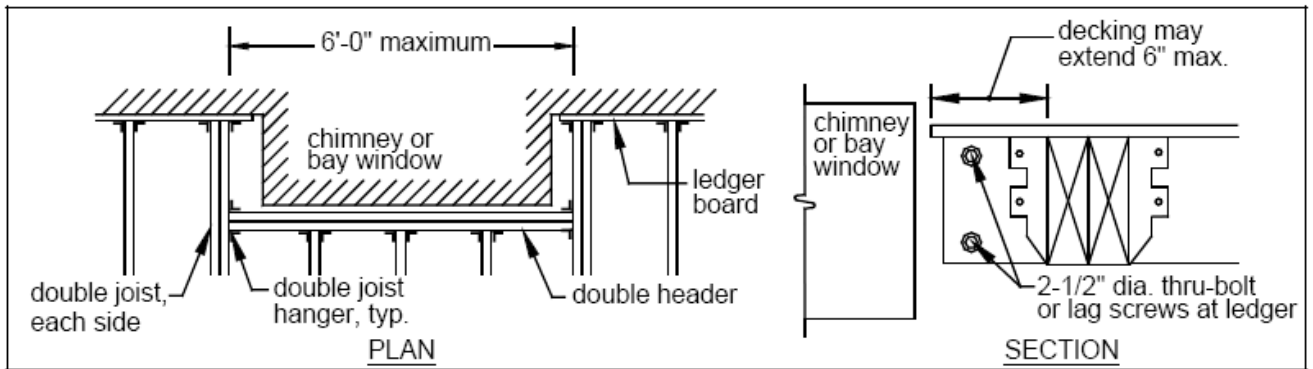

FIGURE 34: REQUIREMENTS FOR FRAMING AT CHIMNEY OR BAY WINDOW